

5.0 WARRANTY

ELECTROMATIC Equipment Co., Inc. (ELECTROMATIC) warrants to the original purchaser that this product is of merchantable quality and confirms in kind and quality with the descriptions and specifications thereof. Product failure or malfunction arising out of any defect in workmanship or material in the product existing at the time of delivery thereof which manifests itself within one year from the sale of such product, shall be remedied by repair or replacement of such product, at ELECTROMATIC's option, except where unauthorized repair, disassembly, tampering, abuse or misapplication has taken place, as determined by ELECTROMATIC. All returns for warranty or non-warranty repairs and/or replacement must be authorized by ELECTROMATIC, in advance, with all repacking and shipping expenses to the address below to be borne by the purchaser.

THE FOREGOING WARRANTY IS IN LIEU OF ALL OTHER WARRANTIES, EXPRESSED OR IMPLIED, INCLUDING BUT NOT LIMITED TO, THE WARRANTY OF MERCHANTABILITY AND FITNESS FOR ANY PARTICULAR PURPOSE OR APPLICATION. ELECTROMATIC SHALL NOT BE RESPONSIBLE NOR LIABLE FOR ANY CONSEQUENTIAL DAMAGE, OF ANY KIND OR NATURE, RESULTING FROM THE USE OF SUPPLIED EQUIPMENT, WHETHER SUCH DAMAGE OCCURS OR IS DISCOVERED BEFORE, UPON OR AFTER REPLACEMENT OR REPAIR, AND WHETHER OR NOT SUCH DAMAGE IS CAUSED BY MANUFACTURER'S OR SUPPLIER'S NEGLIGENCE WITHIN ONE YEAR FROM INVOICE DATE.

Some State jurisdictions or States do not allow the exclusion or limitation of incidental or consequential damages, so the above limitation may not apply to you. The duration of any implied warranty, including, without limitation, fitness for any particular purpose and merchantability with respect to this product, is limited to the duration of the foregoing warranty. Some states do not allow limitations on how long an implied warranty lasts but, notwithstanding, this warranty, in the absence of such limitations, shall extend for one year from the date of invoice.

ELECTROMATIC Equipment Co., Inc.
600 Oakland Ave. Cedarhurst, NY 11516—USA
Tel: 1-800-645-4330/ Tel: 516-295-4300/ Fax: 516-295-4399

Every precaution has been taken in the preparation of this manual. Electromatic Equipment Co., Inc., assumes no responsibility for errors or omissions. Neither is any liability assumed for damages resulting from the use of information contained herein. Any brand or product names mentioned herein are used for identification purposes only, and are trademarks or registered trademarks of their respective holders.

CONTENTS

1.0 Operation	2
1.1 Fastening the MK Tensionmeter	
1.2 Inserting the material to be measured	
1.3 Air Damping (Option)	
1.4 MIN/MAX Contacts	
2.0 Verifying the MK Calibration	5
2.1 Checking Procedure	
3.0 Service and Maintenance	6
3.1 Rollers	
3.2 Cleaning	
3.3 Verification Intervals	
4.0 Specifications	7
4.1 Roller Guides	
4.2 Available Models	
5.0 Warranty	8



CAUTION

Tensions that exceed the tension range of the MK instrument by more than 100% may cause permanent damage to the movement and must be avoided under any circumstances.

1.0 OPERATION

1.1 Fastening the MK Tensionmeter

Two mounting holes are provided for fastening the tensionmeter on site. For the mounting hole dimension, see the figure below.

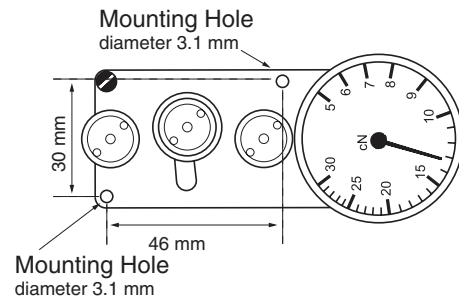

1.2 Inserting the material to be measured

Thread the material to be measured carefully through the measuring roller and roller guides as shown in the figure at right. It is important to ensure that the material runs smoothly through the roller guides and the measuring roller.



CAUTION To avoid damage, do not move the center roller using force.

You can now read the measured tension on the scale.

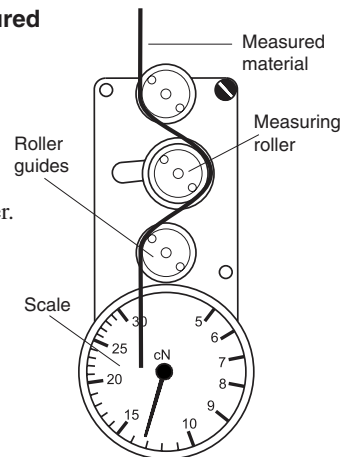

1.3 Air Damping (Optional Accessory code A)

The measuring system of the MK can be factory-equipped with a dashpot. This dashpot makes it possible to absorb approximately 50% of the pointer oscillations. We recommend application of the dashpot in the case of high tension fluctuations (spooling or winding). The setting of the dashpot has to be tuned to the local conditions by experimenting.

4.0 SPECIFICATIONS

Calibration:	According to SCHMIDT factory procedure
Accuracy:	$\pm 1\%$ full scale (FS) or ± 1 graduation on scale
Scale diameter:	43 mm
Temperature range:	10 – 45°C
Air humidity:	85% RH, max.
Housing material:	Plastic (Makrolon)
Housing dimensions:	96mm x 44mm x 2 mm (L x W x H)
Weight, net (gross):	approx. 80 g (200 g)

4.1 Roller Guides

V-grooved	Line Speed M/min max.	Roller Material
Standard	1000	Hardcoated aluminum
Code T	1000	Plastic (POM) black
Code W	1000	Nickel-plated steel

4.2 Available Models

Type	Measuring range cN	**Factory Calibration Material
MK-12	12 – 3	Filament: 25 tex
MK-20	5 – 20	Filament: 25 tex
MK-30	5 – 30	Filament: 25 tex
MK-50	10 – 50	PA: 0.12mm Ø
MK-100	10 – 100	PA: 0.12mm Ø
MK-250	20 – 250	PA: 0.12mm Ø
MK-300	20 – 300	PA: 0.20mm Ø
MK-400	50 – 400	PA: 0.20mm Ø

** Suitable for 95% of applications. PA = Polyamide Monofilament If the material to be measured differs significantly from the SCHMIDT calibration material in diameter, rigidity, shape, etc., we recommend calibration using customer material. For this purpose, a material sample of about 5 m should be supplied. International unit for tension force: 1 cN = 1.02 g = 0.01 N

3.0 SERVICE AND MAINTENANCE

The tension meter is easy to maintain. Depending on operating time and load, the tension meter should be checked according to the locally valid regulations and conditions.

Other testing methods as can cause different measuring readings.

3.1 Rollers

You should regularly inspect the rollers to assure that they are running easily and smoothly. You can replace the rollers yourself, as necessary. When ordering spare rollers, please indicate the tension meter model and the serial number (on the rear side of the tension meter).

Ordering of spare rollers

Model: MK-12 (on the right side of the tension meter)

Serial number: 300 -888888 (on the right side of the tension meter)

Standard rollers: Order number R12013

3.2 Cleaning

For cleaning the unit, do not use any AGGRESSIVE SOLVENTS such as trichloroethylene or similar chemicals. NO WARRANTY OR LIABILITY shall be accepted for damage resulting from improper cleaning.

3.3 Verification Intervals

The question of finding the right frequency of calibration accuracy verification depends on several different factors:

- Operating time and load of the SCHMIDT tension meter
- Tolerance band defined by the customer
- Changes of the tolerance band compared to previous verifications of calibration

Therefore, the interval between verifications must be determined by the user's Quality Assurance Department based on the user's experience. Assuming normal operating time and load as well as careful handling of the tension meter, we recommend a verification interval of 1 year.

To set the Dashpot

1. Turn the setscrew clockwise as far as it will go (screw is protected against overturning). The dashpot is now at its maximum setting.
2. Screw the setscrew out again counter-clockwise until the desired damping factor for the scale pointer is achieved.

Note: A change in the damping factor is only possible within the first three counterclockwise revolutions of the setscrew.

3. Turn the setscrew clockwise to increase damping.
4. Turn the setscrew counterclockwise to reduce damping.

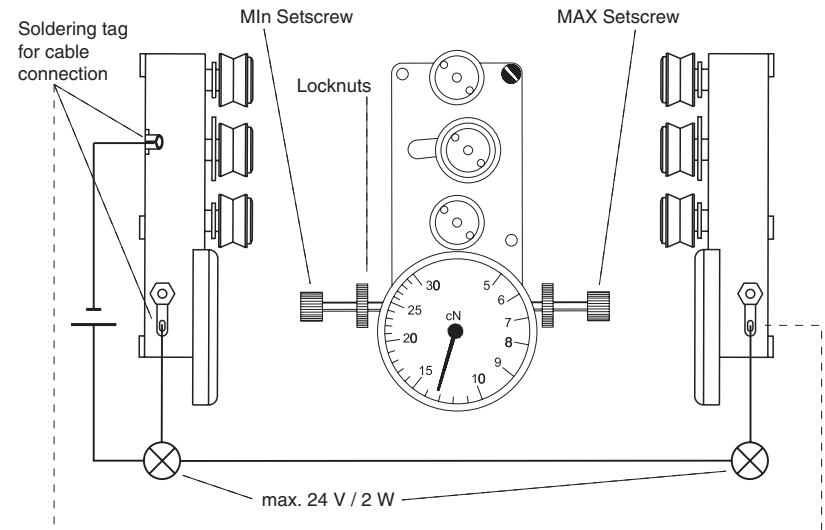
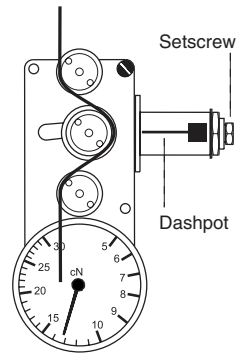

1.4 Min/Max Contacts (Optional Accessory Code D)

Your MK tensionmeter can be factory-equipped with Min/Max tension-detecting contacts which allow you to monitor the tolerance limits for the measured tension. We recommend application of the tension-detecting screw contacts in case of automated production sequences. These factory-installed

contacts are free from potential. Instead of the the lamps shown in the illustration shown on page 3, it is, of course, possible to connect other equipment, such as bell, horn, relay, etc.

The contact load specified in the figure on page 3 of max. 24 V / 2 W must not be exceeded. The setting of the desired tolerance range has to be tuned to the local conditions by experimenting.

To set the MAXIMUM tolerance limit:

1. Loosen the locknut on the MAX setscrew.
2. Turn the setscrew counterclockwise to decrease the MAXIMUM tolerance, or
3. Turn the setscrew clockwise to increase the MAXIMUM tolerance.
4. Tighten the locknut on the MAX setscrew again.

To set the MINIMUM tolerance limit:

1. Loosen the locknut on the MIN setscrew.
2. Turn the setscrew clockwise to decrease the MINIMUM tolerance, or
3. Turn the setscrew counterclockwise to increase the MINIMUM tolerance.
4. Tighten the locknut on the MIN setscrew again.

2.0 VERIFYING THE MK CALIBRATION

All tension meters are calibrated with standard materials—such as polyamide monofilament (PA)— according the factory procedure. Filament sizes are noted in Section 4.2.

Any difference in process material size and rigidity from the standard material may cause a deviation of the accuracy.

In 95 % of all industrial applications the factory calibration has been proven to provide the best results and is used for comparative purposes.

If the process material differs significant in size, rigidity and shape we recommend special calibration using customer's sample. For this purpose a material sample of 5 m should be supplied.

2.1 Checking procedure

1. Suspend a known weight that corresponds to the tension to be measured (pay attention to the correct unit of measure) from the Process material, vertically, as shown in the figure. Always use a fresh portion of the material to be measured.
2. Before the final check, move the Process material slowly up and down to compensate any friction caused by the instrument and thus ensure the repeatability.
3. The tension value should be equal to the value of the suspended weight.

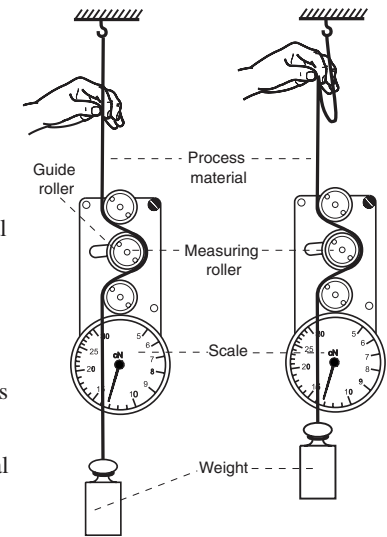

If this procedure shows a deviation beyond the allowable tolerance and a reliable operation is no longer allowed, the instrument has to be recalibrated or repaired.

For recalibration, return the tension meter to the factory.

Model MK TENSIONMETER

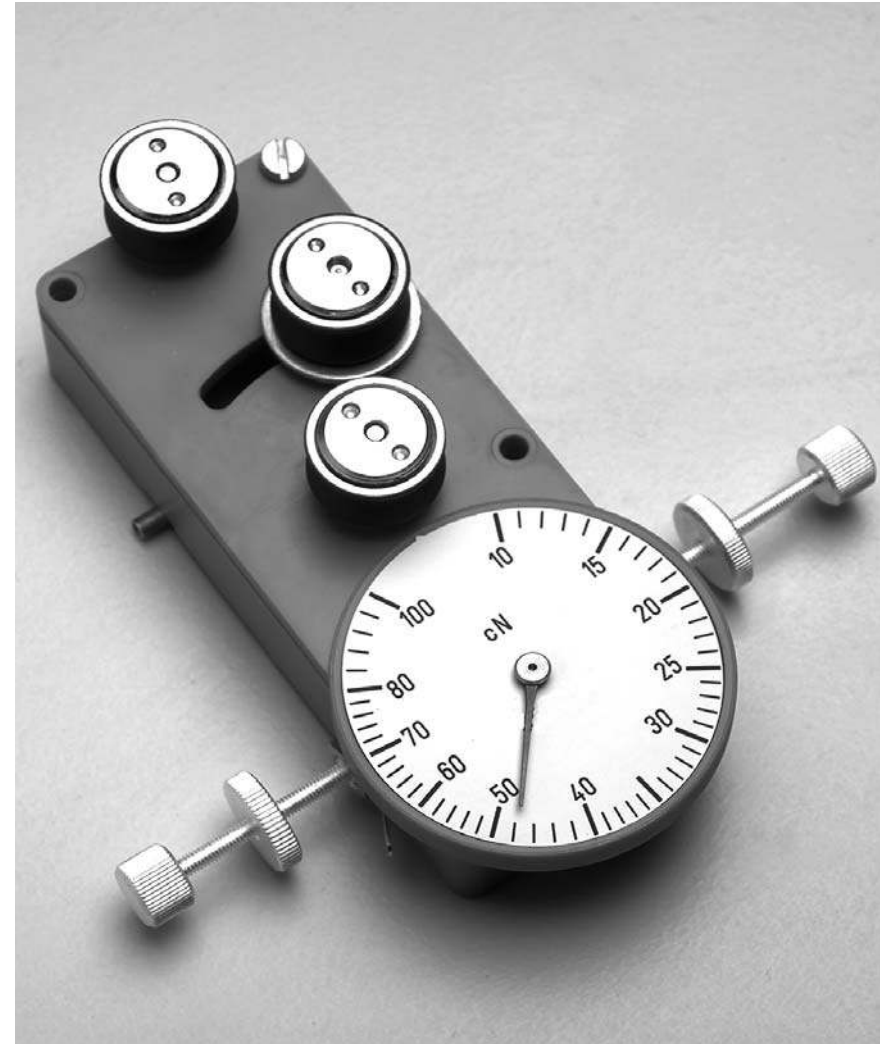

ELECTROMATIC
EQUIPMENT CO., INC.
600 Oakland Ave., Cedarhurst, NY 11516-U.S.A.
TEL: 516-295-4300 • FAX: 516-295-4399